

INSPECTION

1. INSPECT TURN SIGNAL SWITCH CONTINUITY

Switch position	Tester connection	Specified condition
Left turn	1 – 2	Continuity
Neutral	–	No continuity
Right turn	2 – 3	Continuity

If continuity is not as specified, replace the switch.

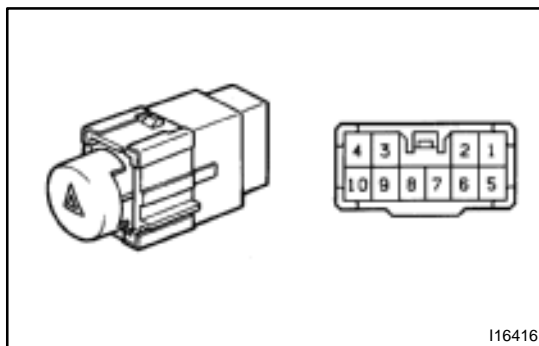

2. INSPECT HAZARD WARNING SWITCH CONTINUITY

Condition	Tester connection	Specified condition
OFF	7 – 10	Continuity
ON	7 – 8, 4 – 5 – 6 – 9	Continuity
Illumination circuit	2 – 3	Continuity

If continuity is not as specified, replace the switch.

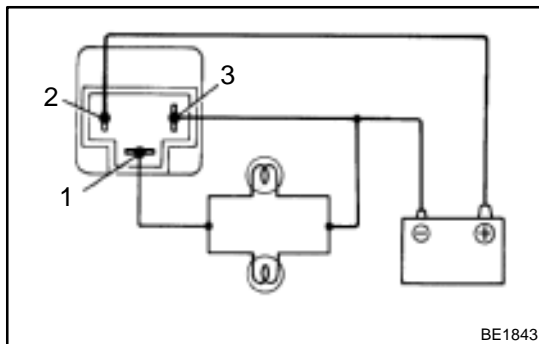

3. INSPECT TURN SIGNAL FLASHER OPERATION

- Connect the positive (+) lead from the battery to terminal 2 and the negative (–) lead to terminal 3.
- Connect the 2 turn signal light bulbs (21 W) parallel to each other to terminals 1 and 3, check that the bulbs flash.

HINT:

- The turn signal lights should flash 60 or 120 times per minute.
- If one of the front or rear turn signal lights has an open circuit, the number of flashers will be more than 140 per minute.

If operation is not as specified, replace the flasher.